

## INSTRUKCJA MONTAŻU INSTALLATION INSTRUCTIONS

nr kat. 0816  
art. N° 0816

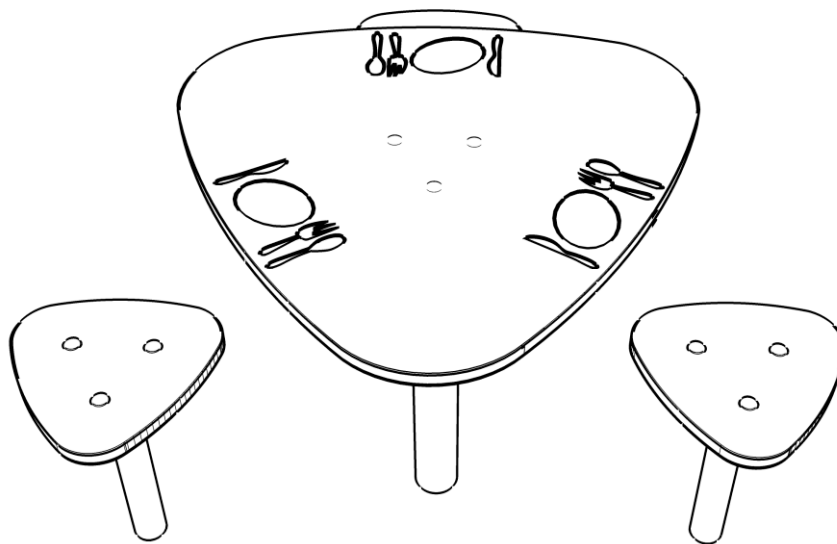

### WYMIARY URZĄDZENIA

dimensions

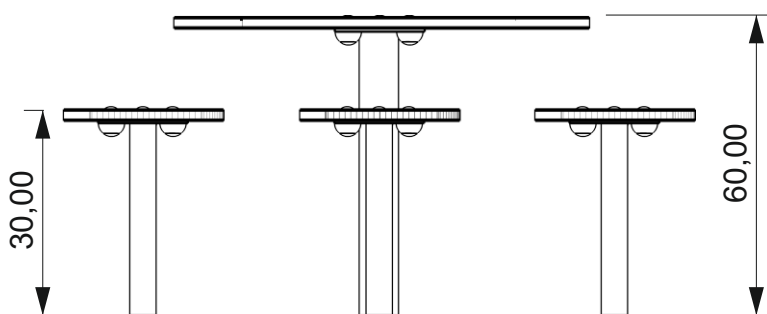
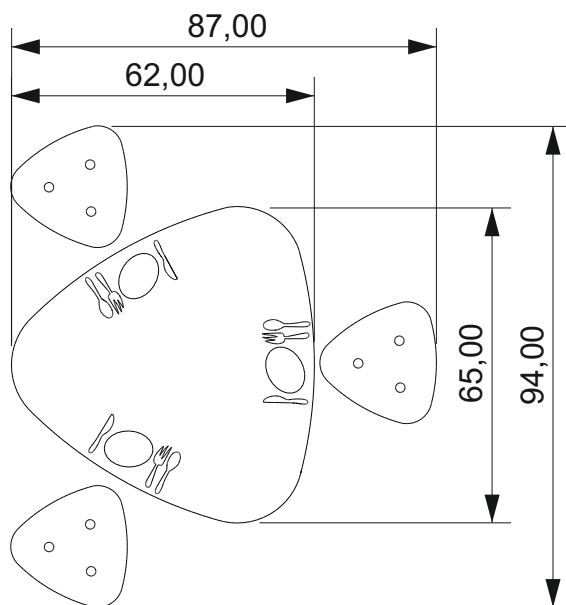

### NARZĘDZIA

tools



# FUNDAMENTY

basement

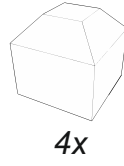
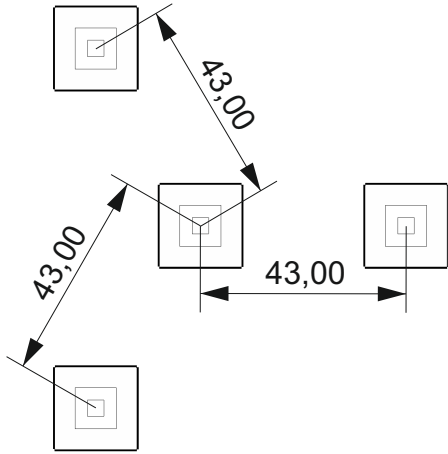

4x 0,05 m<sup>3</sup>

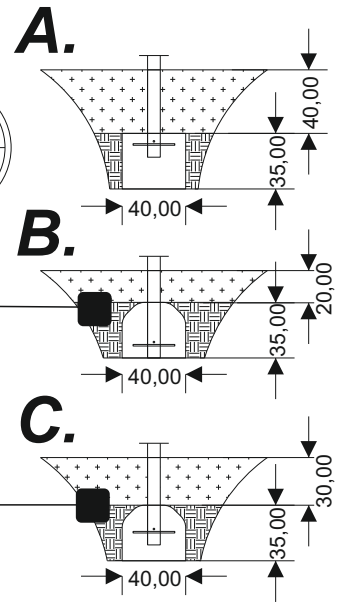

# ELEMENTY SKŁADOWE

components

